

CSO/STORMWATER MANAGEMENT

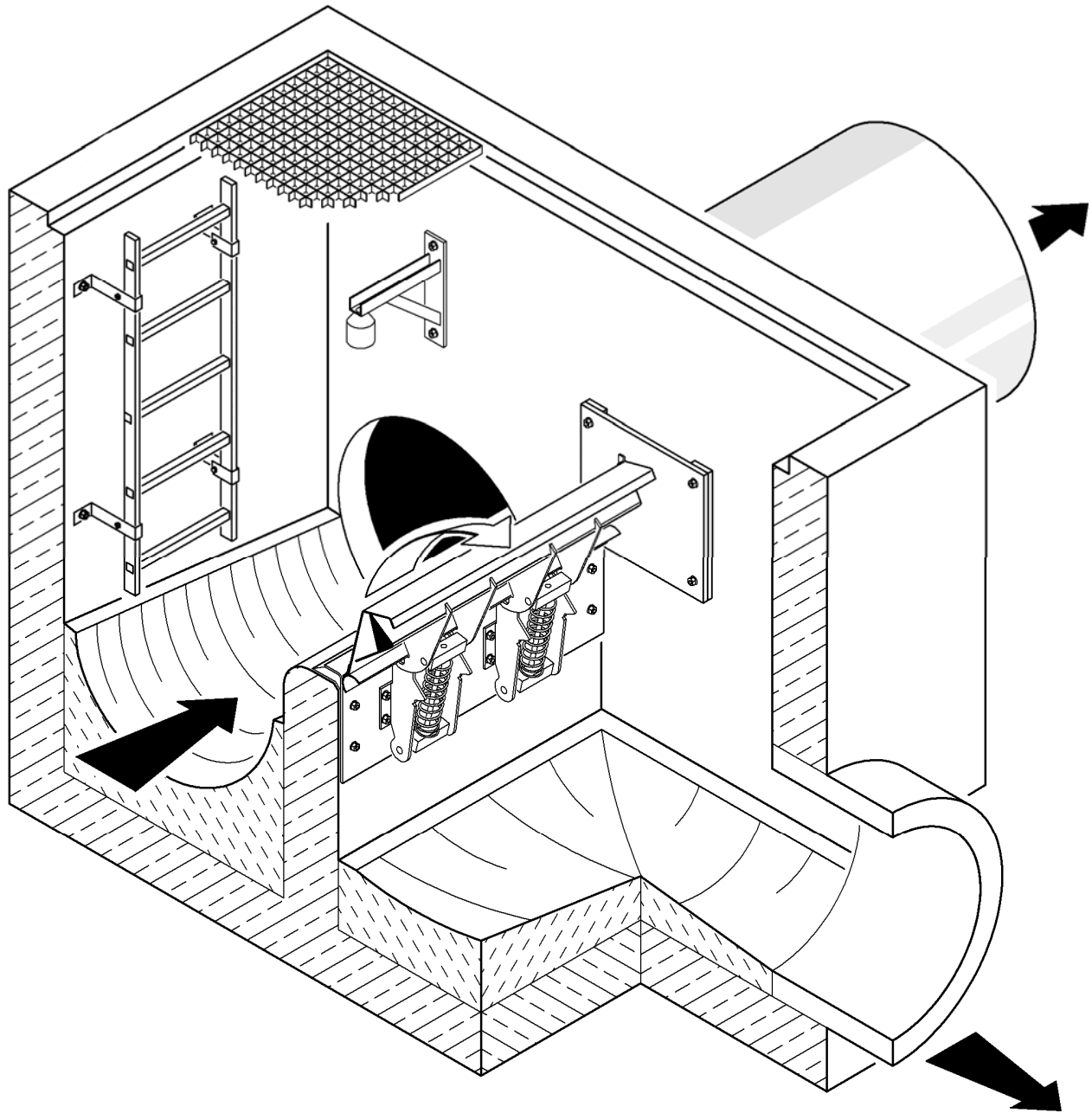

 **HYDROVEX[®]**

Flap Spring-loaded Weir



JOHN MEUNIER

APPLICATION

All Combined Sewer Systems have overflow points to the outfall. When a defined water level is exceeded in the system, the surplus water is overflowed to the receiving waters to avoid overloading of the Sewer Line and WWTP. Most overflow points are equipped with fixed static weirs. The allowable water height used to set the weir level w_o is defined by the acceptable upstream backflow in the sewer line with the design flow Q_b dimensioning = Q_{bu} and the length of weir L .

The height of the w_o weir influences the passive capacity of retention of the line, which is the paramount factor in stormwater retention calculation. To reach an optimal use of the retention volume, long static weirs and their related civil work are required.

With the **HYDROVEX® Flap Spring-loaded Weir**, we present a new type of level control device that is more powerful than a normal static weir. The spring-loaded weir can limit the required water level increase over the weir in order to generate a large overflow. Consequently, more retention volume in the sewer line is gained, while maintaining a safe level of water upstream (**Figure 1**). Contrary to the standard sharp crested weir, water can be overflowed without sucking out the sediment bed load from the sewer line.

CONSTRUCTION

The **HYDROVEX® Flap Spring-loaded Weir** is self-regulating and does not require external energy. Its stainless steel bow-shaped construction is very rigid in torsion and bending. The return mechanism consists of stainless steel compression springs installed under the weir to save space. The unit does not require cables, counterweight, bevel gearboxes and rotating shafts, resulting in a great reliability, long parts life and minimal maintenance.

The construction of the spring-loaded weir is represented in **Figure 2**. A main beam, (1) made up of a profile sheet in the shape of a z, folded in two, is attached by shafts to the back of the concrete weir. We calculate the exact installation elevation of the unit according to each project to generate the appropriate retention level.

The flap plate (2) pivots on bearings attached to the main beam. The flap plate is composed of reinforcing beams tied to the spring supports (3). The bearings of the weir (4) are made of stainless steel and designed for large loads. The return mechanism includes one or more springs (5) made of stainless steel. The springs are built on a spring internal guide (6). The geometry of construction and the characteristics of the springs guarantee the flow curve.

The side plates of the spring-loaded weir are made of PEHD elements (7). These can be connected to the main beam and maintained by ties or be anchored directly on the existing side walls. The anchoring system supplies leveling to guarantee a reduced friction of the side elastomer EPDM joints (8) made to resist wastewater and frost.

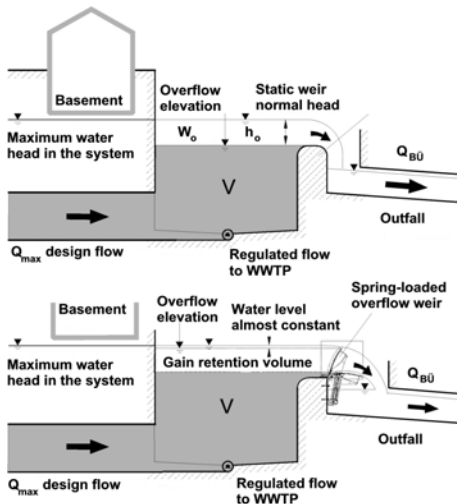

Figure 1: Demonstration of the efficiency of the HYDROVEX® Flap Spring-loaded Weir compared to a static weir

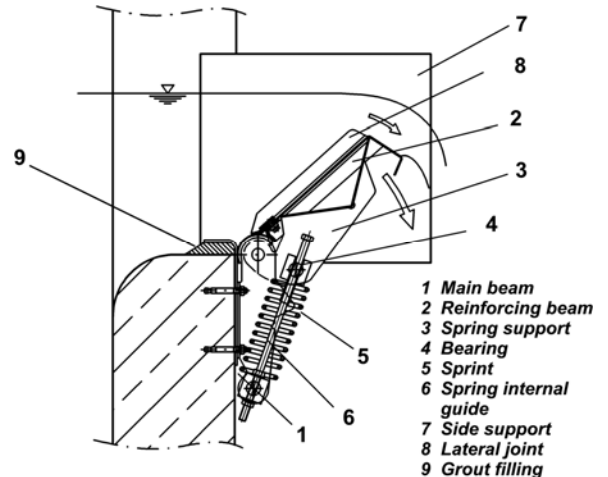

Figure 2: Sections of the HYDROVEX® Flap Spring-loaded Weir

A gap of 1" to 1 1/4" between the side plates and the concrete wall is required. This gap serves mainly to adjust the unit inside the concrete openings work, but also as ventilation of the water flow, which passes over the weir to limit the oscillation of the unit. The gap is sealed to the upstream side by plastic strips to prevent water leaks.

The main beam (1) is sealed in place with grout (9). This also supplies good support for the vertical loads on the unit.

OPERATION

The construction simplicity of the **HYDROVEX® Flap** Spring-loaded Weir guarantees great reliability and allows for quick assembly. The form of the weir, the choice of material, as well as return mechanism conception, is the result of numerous laboratory tests and calculations. Behind this very simple construction is a very complex relationship between the static and dynamic hydraulic forces of the overflow water and the passive compression load of the springs in each position of the weir.

Resting Position:

When the **HYDROVEX® Flap** Spring-loaded Weir is in resting position, the pre-stressed springs are at full extension as long as there is no water level increase.

Beginning of overflow:

When the activation water level w_{min} is reached, the hydrostatic forces of water make the weir yield downwards. The dynamic forces involved compress the spring mechanism to a new balance position.

Rising Water Level:

If the water level increases slightly, then the spring-loaded weir will yield more to the bottom and increase the water discharge section. The load curve in this case is practically horizontal (**Figure 5**), meaning that there is almost no water level increase, even though the discharged volume of water increases rapidly.

Maximum flow:

At maximum capacity, the spring-loaded weir is pressed against a mechanical stop unit, which limits the maximum bending. It is possible to overload the weir after this extreme position is reached and a much more significant flow can be created. However, once the springs are completely compressed, the flow can continue to increase, in spite of a reduction of effectiveness, it remains more efficient than a fixed weir, see **Figure 5**.

Decreasing Water Level:

When the flow decreases, the water level drops slowly and the forces on the weir are slackened. The weir progressively goes back to its resting position. As soon as the home position is reached, the overflow stops.

The **HYDROVEX® Flap** Spring-loaded Weir shows a light and inevitable friction on the side supports, creating a small hysteresis of load Δh_{hy} , like all valve-type level regulators without external energy. This implies that the level of water at end of discharge is somewhat lower than at beginning of discharge. However, due to its construction quality, the **HYDROVEX® Flap** Spring-loaded Weir has a minimum friction and this hysteresis is limited to only some fraction of inches of the available water height, thus causing no operation problem. A certain hysteresis caused by friction is even necessary, as it prevents dynamic problems such as oscillations of the weir (damping effect of the spring motion).

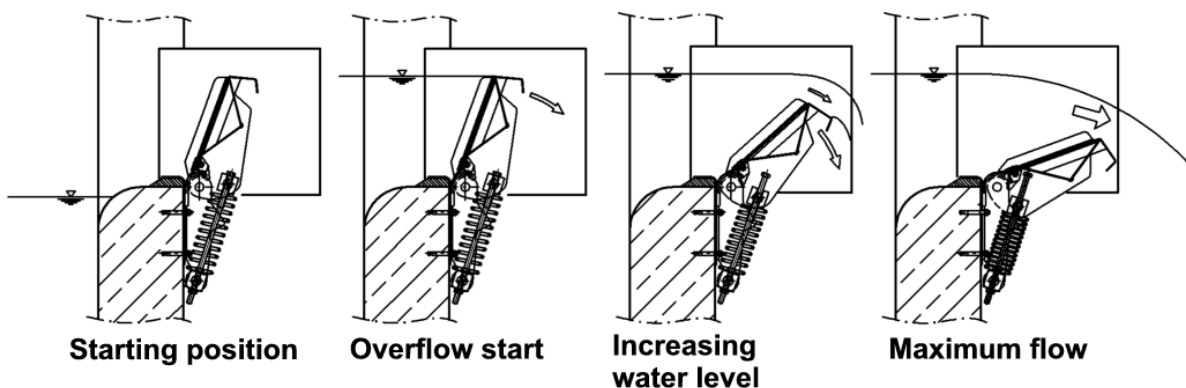

Figure 3 : Various operating phases of the spring overflow

We bring your attention to the fact that this device will cause brutal and sudden overflows. This implies that public security must be checked as well as the overall evacuation capacity of the downstream structures.

Backwash prevention:

The spring-loaded weir, subject to a backflow from the downstream side, can be modified to prevent water from returning in the sewer line. A higher lip seal is then added where the spring-loaded weir is in a resting position. The side plates for this option are strengthened to resist water loads in one way or the other. The spring-loaded weir can thus be used as a backflow prevention unit.

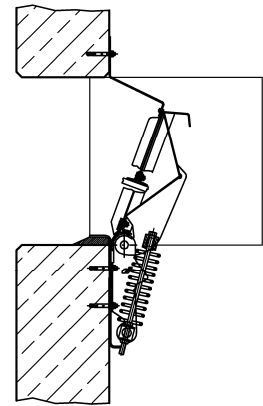

Figure 4: Use of HYDROVEX® Flap Spring-loaded Weir as backwash device

MEASURE OF DISCHARGE

The measure of overflowed water can be done by using the relationship between the angle of bending of the weir and the flow that passes the weir at a relatively constant water level. To do this, the weir plate has to be supplied with an angle indicator fixed on the body of the weir. Water passes over the weir only when it is not in resting position. If only the number and the duration of the activity of the discharge are required, then a limit switch is enough instead of the angle indicator.

MODELS AVAILABLE

Three standard models of HYDROVEX® Flap Spring-loaded Weirs are available and are represented in the table below. The specific design flow, indicated Q per meter length, is the flow for which the weir is in maximum bending position. The flows of weirs FSK 300 and FSK 700 meets chart ATV A 166, concerning the maximum allowable flows of the outfalls.

Type	Specific Design Flow Q ls-m (cfs)
FSK 300	300 (10.6)
FSK 465	465 (16.4)
FSK 700	700 (24.7)

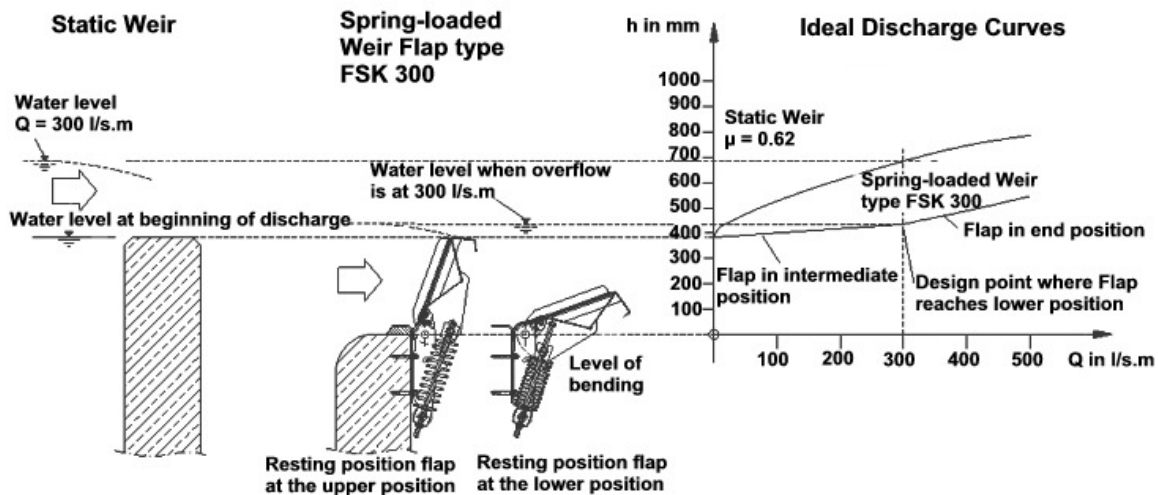

Figure 5: Flow chart of the HYDROVEX® Flap Spring-loaded Weir

John Meunier Inc.

ISO 9001 : 2000

Head Office

4105 Sartelon
 Saint-Laurent (Quebec) Canada H4S 2B3
 Tel.: 514-334-7230 www.johnmeunier.com
 Fax: 514-334-5070 cs@johnmeunier.com

Ontario Office

2000 Argenta Road, Plaza 4, Unit 430
 Mississauga (Ontario) Canada L5N 1W1
 Tel.: 905-286-4846 www.johnmeunier.com
 Fax: 905-286-0488 ontario@johnmeunier.com

USA Office

2209 Menlo Avenue
 Glenside, PA USA 19038
 Tel.: 412-417-6614 www.johnmeunier.com
 Fax: 215-885-4741 asteel@johnmeunier.com

