

# Wallace & Tiernan® Liquid Feed Systems Premia® 75 Solenoid Metering Pumps

## Introduction

Premia® 75 solenoid metering pumps include a comprehensive selection of units for even the most demanding applications. Whether they call for simple manual operation or complex process control, there's an economical Premia® 75 solenoid pump to handle it with ease. Choose from six distinct models offering everything from simple manual control to battery powered operation, to 1000:1 turndown with our microprocessor version. Then choose from a broad range of liquid end materials, options and accessories to handle even the most critical applications. For the utmost in economy, reliability, and true metering performance, choose Premia®75 solenoid pumps.

## Key Benefits

- Six models for capacities up to 95 lph (25 gph) and back pressures to 21 bar (300 psi)
- High metering accuracy longevity and leak-free performance
- Wide range of accessories and options
- Certified by ETL to UL Standard 778 for indoor and outdoor service; CSA Standard C22.2 and NSF 50
- Specified capacities and pressures will not derate, even during extended service
- Manual to automatic operation available



[Product Sheet](#)

Water Technologies

**SIEMENS**

## Models and Features

### Mono

- Four sizes to handle capacities to 5.04 lph (1.25 gph), back pressures to 5.6 bar (80 psi).
- Manual control by on-line adjustable stroke length, fixed stroke frequency.
- Optional external pulse input control
- 5:1 turndown ratio.
- Metering performance reproducible to within  $\pm 3\%$  of maximum capacity.
- For more information, request publication WT.460.150.001. UA.PS.

### Econo

- Ten sizes to handle capacities to 7.6 lph (2 gph), back pressures to 16 bar (250 psi).
- Manual control by on-line adjustable stroke length and stroke frequency.
- Optional external pulse input control.
- 100:1 turndown ratio.
- Metering performance reproducible to within  $\pm 3\%$  of maximum capacity.
- For more information, request publication WT.460.150.001. UA.PS.

### Mini

- Nineteen sizes to handle capacities to 95 lph (25 gph), back pressures to 21 bar (300 psi).
- Manual control by on-line adjustable stroke length and stroke frequency.
- Optional external pulse input control.
- 100:1 turndown ratio.
- Metering performance reproducible to within  $\pm 3\%$  of maximum capacity.
- For more information, request publication WT.460.150.002. UA.PS.

### Mini DC

- Four sizes to handle capacities to 7 lph (1.85 gph), back pressures to 10 bar (150 psi).
- Operates from a 12 VDC supply.
- Manual control by on-line adjustable stroke length and stroke frequency.
- 100:1 turndown ratio.
- Metering performance reproducible to within  $\pm 3\%$  of maximum capacity.
- For more information, request publication WT.460.150.002. UA.PS.

### Mega

- Nineteen sizes to handle capacities to 79 lph (25 gph), back pressure to 21 bar (300 psi).
- Manual control by on-line adjustable stroke length and stroke frequency.
- Optional external control by 4-20 mA input or pulse input, with stop function.
- 100:1 turndown ratio.
- Metering performance reproducible to within  $\pm 2\%$  of maximum capacity.
- Panel mounted circuit breaker.
- For more information, request publication WT.460.150.003. UA.PS.

### Micro

- Nineteen sizes to handle capacities to 78.85 lph (20.83 gph), back pressure to 21 bar (300 psi).
- Manual control by on-line adjustable stroke length and stroke frequency; stroke counting and time interval operation available
- External control by 4-20 mA or 20-4 mA input or pulse input, with ratio control and stop function.
- 100:1 turndown ratio.
- Metering performance reproducible to within  $\pm 2\%$  of maximum capacity.
- Panel mounted circuit breaker.
- Extended two year warranty on electronic circuit board.
- For more information, request publication WT.460.150.003. UA.PS.



*Mega and Micro Series*



*Mono, Econo, Mini,  
and Mini-DC Series*

1. A standard 3-function valve is provided with every Premia® 75 pump. To enhance performance and provide a more convenient installation, an optional 5-function valve is available. This neat, compact device provides:

- Pressure relief - Relieves excess pressure that may build in the discharge line, protecting tubing and connections.
- Back Pressure - Creates a discharge restriction for repeatable output. Allows metering into atmosphere.
- Anti-Syphon - Prevents syphoning through the pump when the point of injection is below the pump, or into the suction line of another pump.
- Pumphead Air Bleed - Used as a priming aid to manually remove air from the pumphead
- Discharge Drain - Depressurizes and drains the discharge line without loosening tubing and connections, or exposing the operator to chemical solutions.

2. High precision guided ball and seat cartridge valves provide a superior seal, reproducible metering accuracy and fast, foolproof service. Single and double ball versions are available to handle mild solutions, aggressive chemicals and viscosities up to 10,000 cps.

3. A precision engineered straight through flow path provides the utmost in efficient fluid metering. Standard liquid end arrangements can handle viscosities up to 3,000 cps. With spring loaded valves, Premia® 75 solenoid pumps can handle viscosities up to 10,000 cps.

4. Our premium composite diaphragm is manufactured to stringent specifications to ensure long life, even under the most demanding applications. The design incorporates teflon-facing, for the highest degree of chemical resistance and nylon reinforcements, all bonded to a preformed elastomeric support. We've added convolutions for unconstrained rolling action, an integral O-ring for complete sealing and a brass insert to assure volumetric accuracy even at varying discharge pressures.

5. Choose from a wide array of liquid end materials, including SAN for integral sight flow indication, PVC, Polyvinylidene Fluoride, 316 SS and Glass-filled Polypropylene. For fluids that entrain air, select our PVC auto degasifying liquid end, available in capacities up to 6.94 lph/1.83 gph.

6. Our solenoid is separately encapsulated in a fin-cooled, thermo-conductive enclosure that effectively dissipates heat. The result is a hot-rated pump. Capacities and pressures do not derate, even over extended use.

7. Circuit boards used in Premia® 75 pumps utilize state-of-the-art electronics to ensure performance and dependability. Our timing circuit is virtually unaffected by temperature, EMI and other electrical disturbances. A transient voltage suppressor protects electronics. Components are surface mounted to reduce wired connections and improve reliability.

8. Our corrosion resistant glass-filled polyester enclosure is certified by ETL to UL standard 778 for indoor and outdoor applications; CSA standard C22.2 and NSF standard 50.

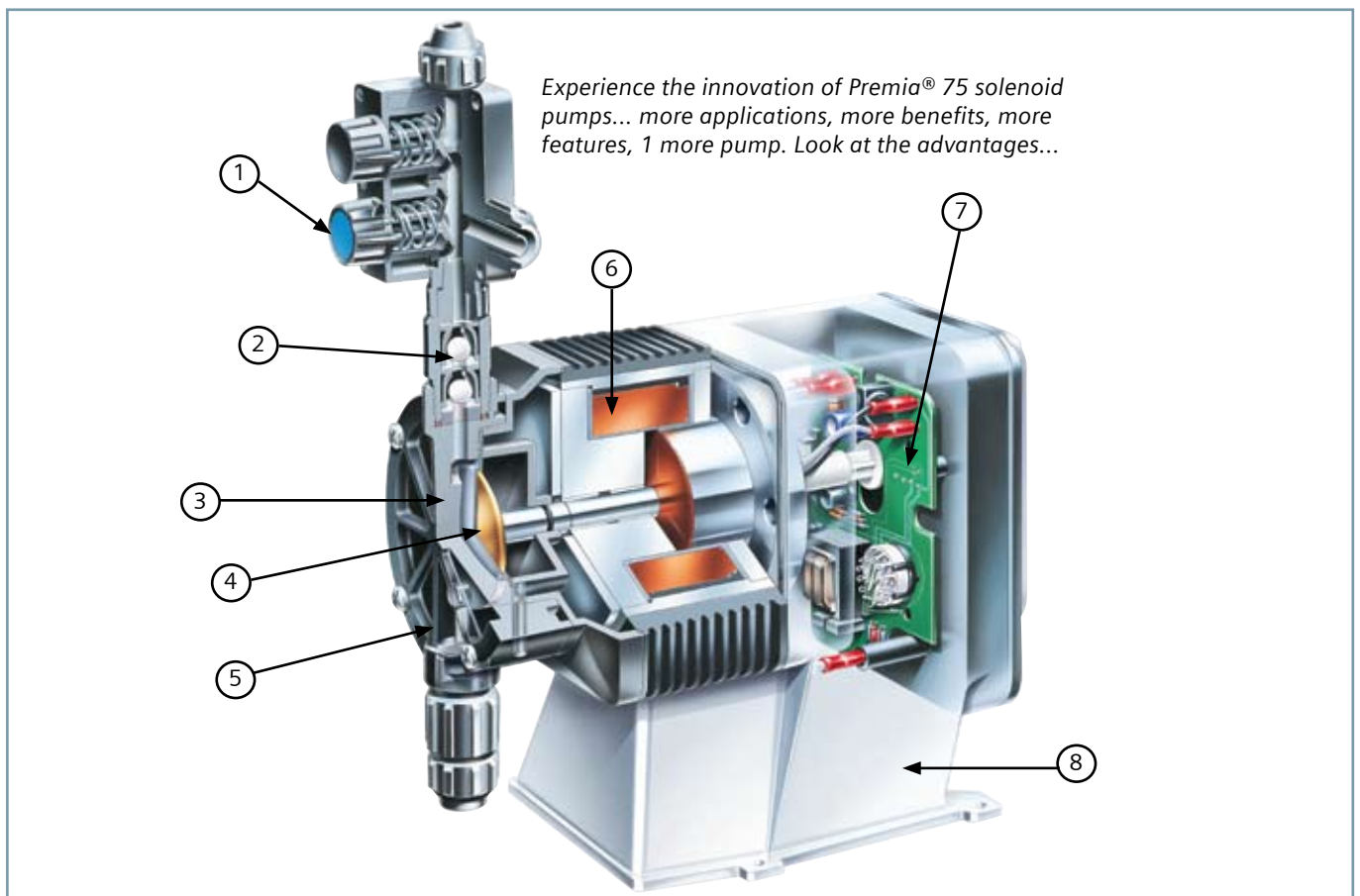

## Pump Heads and Accessories

Liquid end materials available

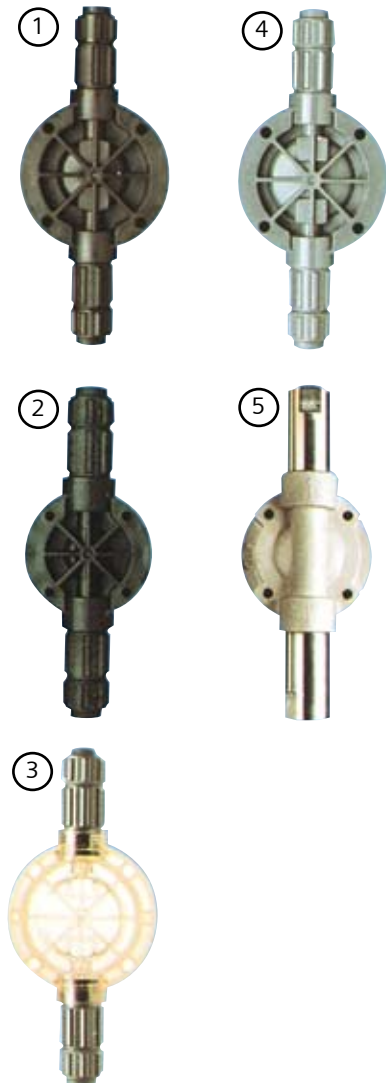

1. Glass-filled polypropylene (GFPPPL)
2. Polyvinylidene (PVDF)
3. Styrene-Acrylonitrile (SAM)
4. PVC
5. 316 Stainless Steel

## Total Solutions

### Chemical Metering Systems

Low cost tank feed systems can be custom configured from standard stock components including tanks, mixers, and a wide range of controls. All systems are shipped assembled, prewired and ready to install. Reference WT.460.150.004. UA.PS for more information.

### Accessories

Our comprehensive range of coordinated accessories provide the ability to produce the best possible installation. Choose from liquid level controllers, flowmeter contactors, flow indicators, wall mounting brackets, bulkhead fittings, reed capsule switches, bleed valves, pressure relief valves, test kits, five function valves, corporation stops and many more. Reference WT.460.150.004. UA.PS and WT.460.150.007.UA.PS for more information.

### PM Kit® Package

Preventive Maintenance kits contain original factory replacements for those parts most susceptible to wear. They facilitate scheduled maintenance and help maintain equipment in good working order eliminating equipment breakdowns and costly downtime.

Siemens  
Water Technologies

Germany  
+49 8221 9040  
wtger.water@siemens.com

United Kingdom  
+44 1732 771777  
wtuk.water@siemens.com

USA  
+1 800 809 0971  
stranco.water@siemens.com

© 2008 Siemens Water Technologies Corp.  
Literature No.: WT.460.150.000.UA.PS.0309  
Subject to change without prior notice.

Wallace and Tiernan, PM Kit, and Premia are trademarks of Siemens, its subsidiaries or affiliates. ETL is a trademark of Intertek Testing Services NA, Inc. UL is a trademark of Underwriters Laboratories, Inc. CSA is a trademark of Canadian Standards Association. NSF is a trademark of NSF International.

The information provided in this literature contains merely general descriptions or characteristics of performance which in actual case of use do not always apply as described or which may change as a result of further development of the products. An obligation to provide the respective characteristics shall only exist if expressly agreed in the terms of the contract.