

Snap-Cap *Plus 5* DIFFUSERS

THE NEW SNAP-CAP "PLUS 5" represents a substantial advancement in the art of diffuser design. The major improvement is in the snap-on check diaphragm cap which is now manufactured from a new, specially compounded, space-age EPDM-based thermoplastic rubber that provides extended life and improved performance.

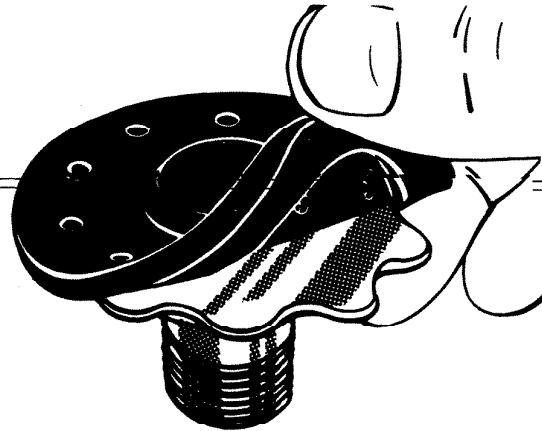

The Snap-Cap "Plus 5" Diffuser consists of two simple parts, the support base and a flexible snap-on check diaphragm. During aeration, the diaphragm lifts from the base, allowing the air to exit through the orifices in the diaphragm. When air stops, the diaphragm is instantly seated against the base by the pressure head of liquid, preventing backflow and clogging. The novel edge design of the diffuser locks on the removable diaphragm to avoid blowoff during unusual pressure surges. Diffusers are available with 3/4" and 3/8" NPT threads in Celcon plastic base and stainless steel base models. Model 750 diffusers will handle air flows to 10 CFM Model 375 diffusers will handle flows to 5 CFM.

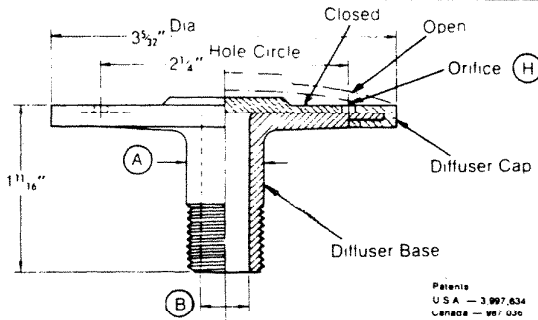

SPECIFICATION DATA

Base Model	T NPT	A	B	H		Cap Model No.
				Size	No.	
375	3/8"	1 1/8"	3/16"	3/16"	10	10
750	3/4"	1 1/4"	1/8"	3/16"	10	10

Patents
U.S.A. — 3,997,634
Canada — 987,030

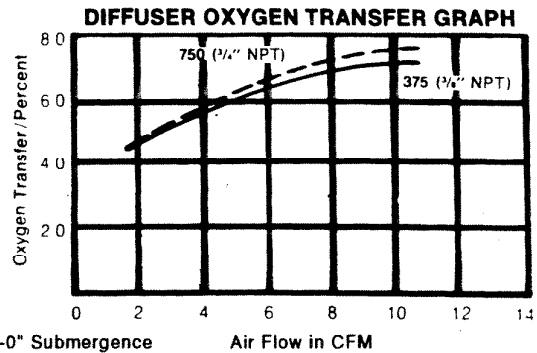
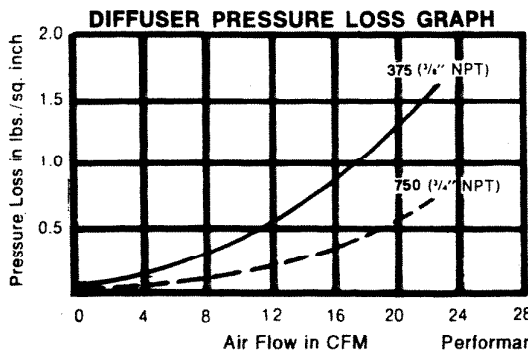

MODEL SELECTION

