



**USFilter**

RETROFIT CERAMIC DOMES

WITH FLEXDOME™

FINE BUBBLE DIFFUSERS



Typical FlexDisc installation.

*Moving to the latest membrane technology once meant starting from scratch. But FlexDome changed that. Its innovative, patented\* bolt-on design allows you to replace just your ceramic dome media – keeping the rest of the piping systems intact. No modifications required... a first in membrane diffuser engineering. In fact, so simple is the installation of FlexDome, it actually takes less time than cleaning your existing ceramic dome system. Give it a try. We'll be glad to send samples for your review.*

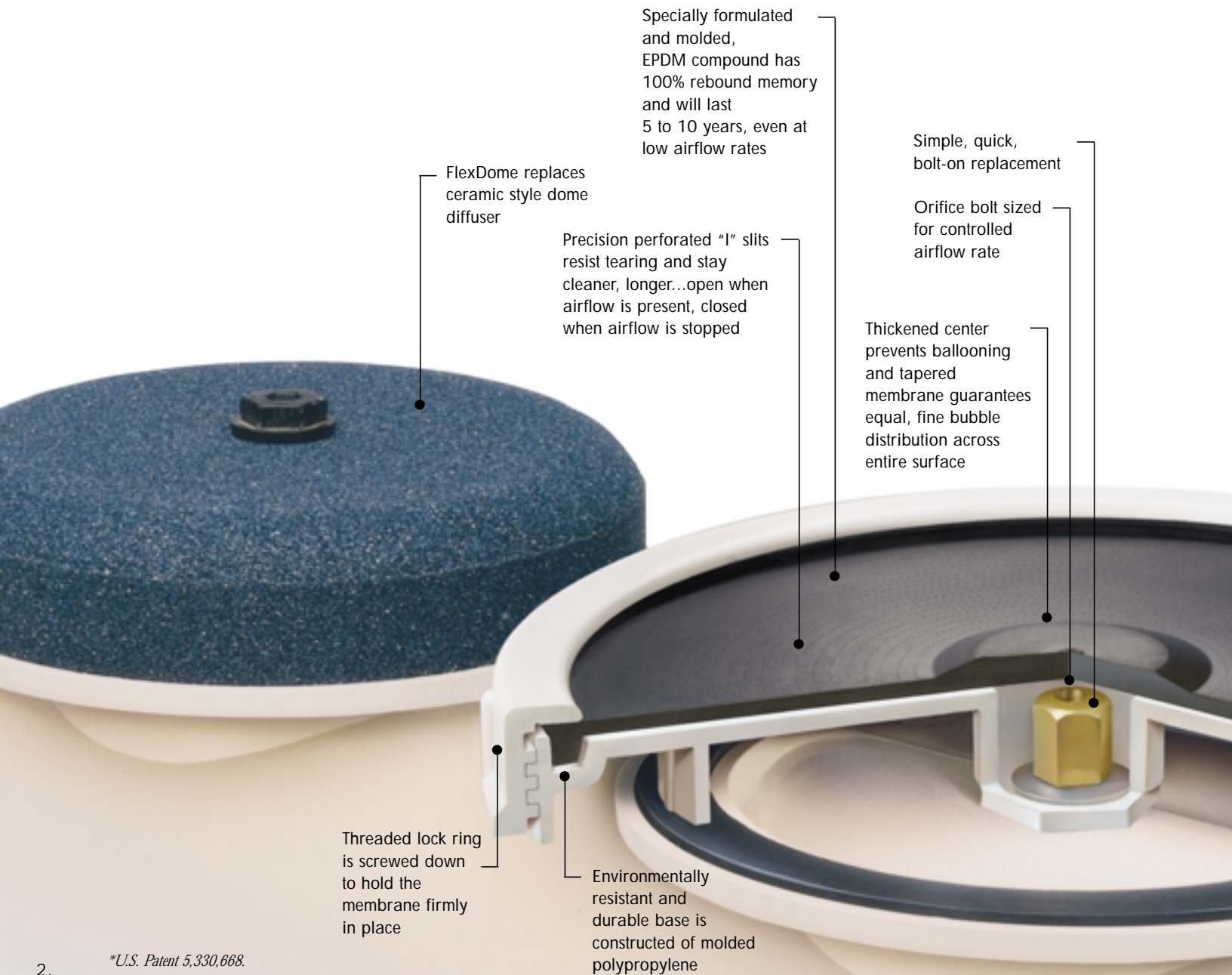

\*U.S. Patent 5,330,668.

CUTS MAINTENANCE  
AND DOWNTIME

FlexDome offers dramatically decreased maintenance and downtime as compared to ceramic dome systems, which require regular cleaning to maintain performance. To clean ceramic domes requires draining the tanks, hose cleaning and spraying with dangerous acids or gases. FlexDome with its smooth outer surface, uniform bubble distribution and continuous flexing of the rubber membrane eliminates build-up of any type.

The FlexDome's unique sealing action when the airflow is stopped eliminates plugging and filling of the headers with water which is common with ceramic domes, assuring a lifetime of efficient, maintenance free performance.

Converting your existing ceramic coarse bubble domes to FlexDome fine bubble diffusers is as simple as 1-2-3.

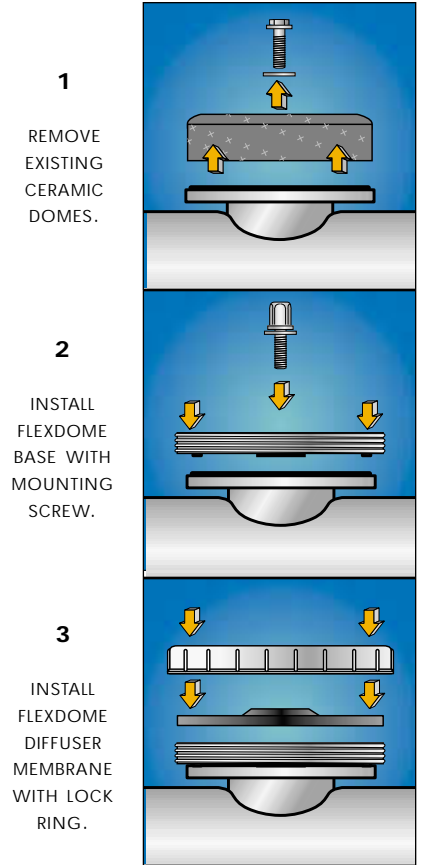

Entire removal and installation takes less than two minutes per dome.

IMPROVES PERFORMANCE



When compared to ceramic domes, the highly efficient FlexDome will cut your electric utility costs by 25% to 40% (see Comparison Chart). Ceramic dome diffusers with their rough surfaces and non-uniform air distribution encourage biogrowth which results in reduced oxygen transfer efficiency and plugging. The higher oxygen transfer efficiencies

maintained over the long term by FlexDome will improve effluent quality and permit greater process flows.

The performance properties of FlexDome diffusers greatly exceed in-service ceramic domes.

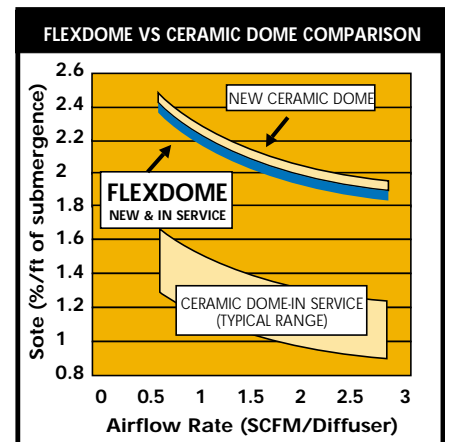

*USFilter offers the most complete line of fine and coarse bubble, plastic, stainless steel and membrane/ceramic air diffusers of any company in the industry, guaranteeing you'll find the right diffuser for your application. We also offer full technical support to assist you with everything from air diffuser selection to complete aeration piping systems design. For new installations, retrofit, or replacement, we're your one source.*

Coarse Bubble Diffusers	Fine Bubble Diffusers
 <p>SED DIFFUSER</p>	 <p>FLEXDISC DIFFUSER (THREADED CONNECTION)</p>
 <p>VARIAIR DIFFUSER</p>	 <p>FLEXDOME DIFFUSER (CERAMIC DOME REPLACEMENT)</p>
 <p>SNAP-CAP DIFFUSER</p>	
 <p>AIRSEAL DIFFUSER</p>	 <p>DUALAIR MEMBRANE &amp; CERAMIC DIFFUSER</p>
 <p>WIDEBAND STAINLESS STEEL DIFFUSER</p>	
 <p>AIRBAND WIDEBAND PLASTIC DIFFUSER</p>	 <p>FLEXLINE TUBULAR DIFFUSER</p>

To find out more about how to put USFilter to work for you, contact us at



Envirex Diffused Air Products  
 P.O. Box 1604  
 Waukesha, WI 53189  
 877.616.3327 *toll free*  
 262.547.0141 *phone*  
 262.521.8338 *fax*  
 envirexdiffusedair@usfilter.com *e-mail*

[www.usfilterenvirex.com](http://www.usfilterenvirex.com)  
 ©2000USFilter

Products manufactured and marketed by USFilter's Envirex Products are protected by patents issued or pending in the United States and other countries.